

Service Schematics



Introduction

IMPORTANT:

This document is intended for use by authorized NOKIA service centers only.

“Service Schematics” was created with focus on customer care.
The purpose of this document is to provide further technical repair information for NOKIA mobile phones on Level 3/4 service activities.
It contains additional information such as e.g. “Component finder”.

Saving process time and improving the repair quality is the aim of this document.
It is to be used additionally to the service manual and other training or service information such as Service Bulletins.

While every endeavour has been made to ensure the accuracy of this document, some errors may exist. If the reader finds any errors, NOKIA shall be notified in writing.

Please send E-Mail to: TrainingAndVendor.Development@nokia.com

RM-540

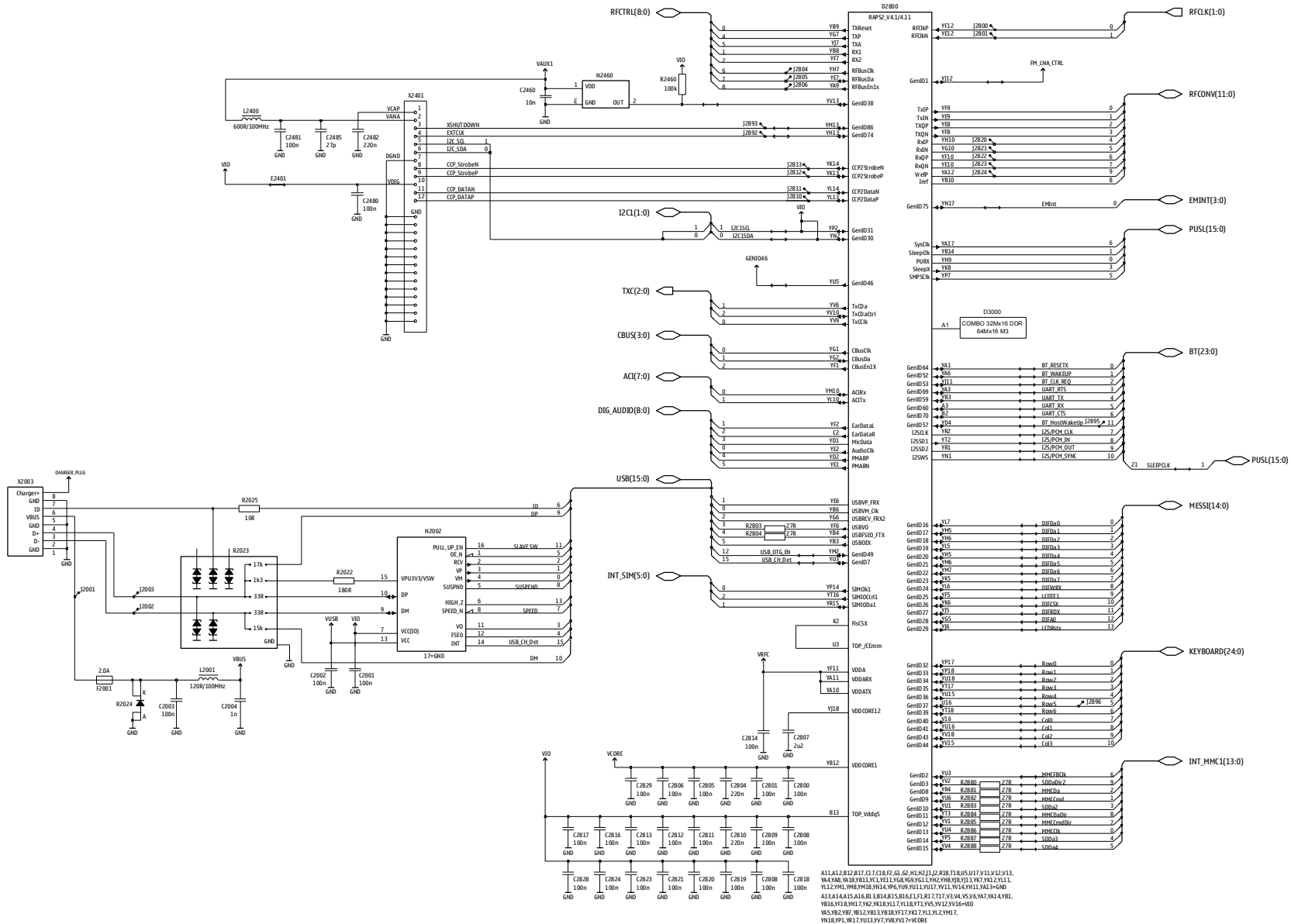

Table of Contents

Front page	1
RAPS, HS USB, Sensors, User Interface	2
GAZOO, Audio, MMC, SIM, Battery	3
Keyboard I/F, Keyboard Backlighting	4
BTHFM	5
RF part	6
Component Finder	7

Copyright © NOKIA

This material, including documentation and any related computer programs is protected by copyright, controlled by NOKIA. All rights are reserved. Copying, including reproducing, modifying, storing, adapting or translating any or all of this material requires the prior written consent of NOKIA. This material also contains company confidential information, which may not be disclosed to others without the prior written consent of NOKIA.



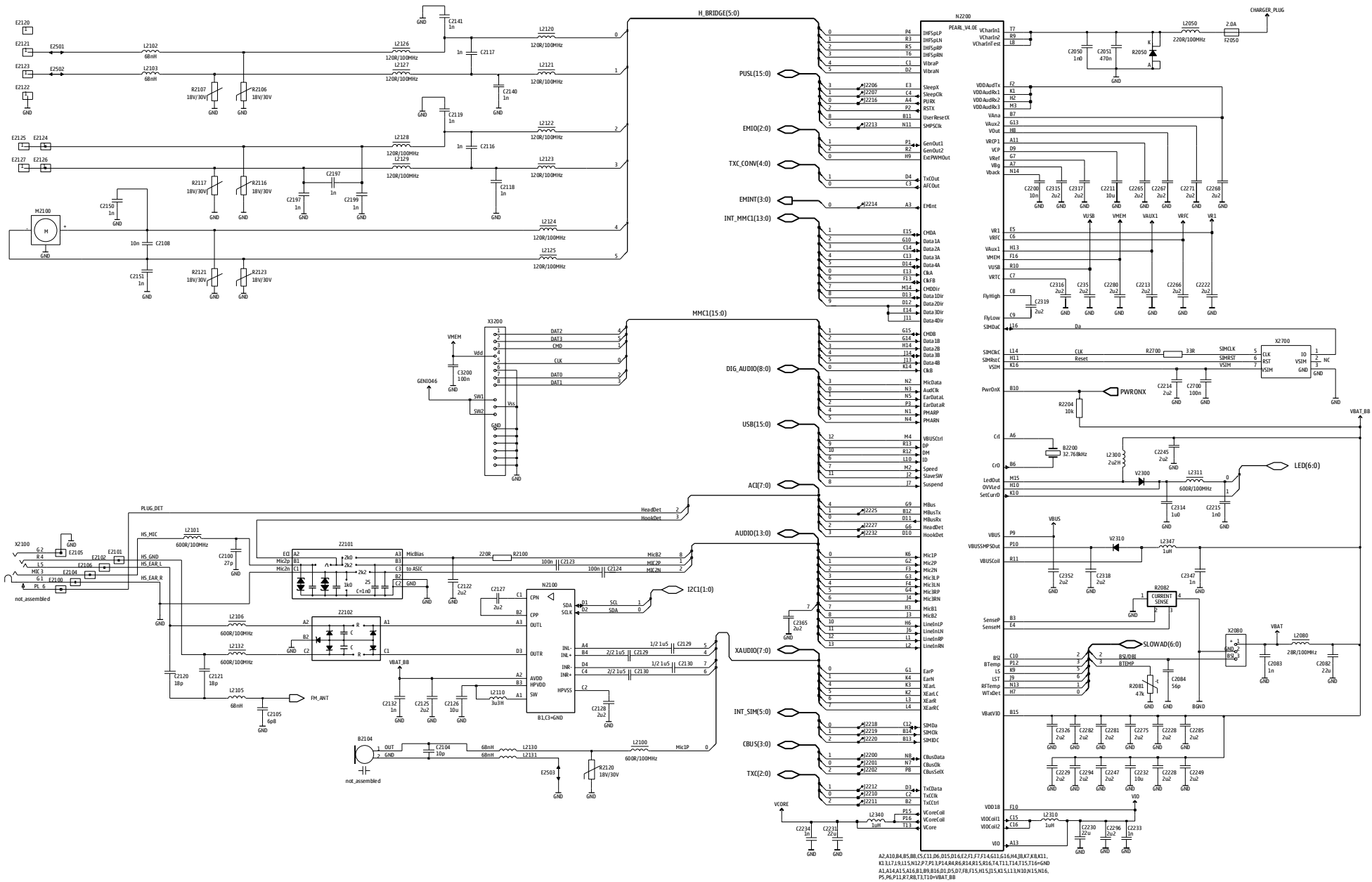

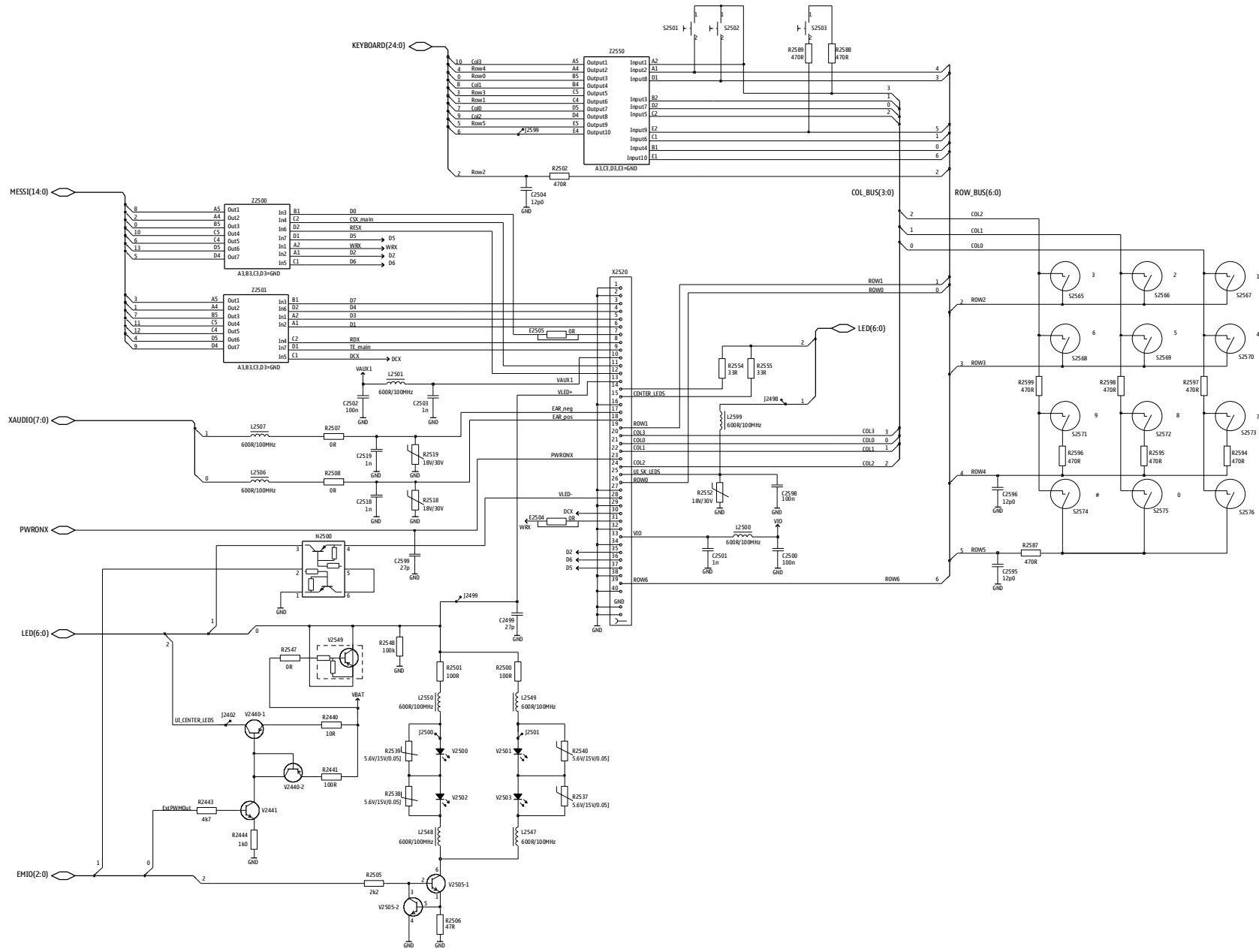

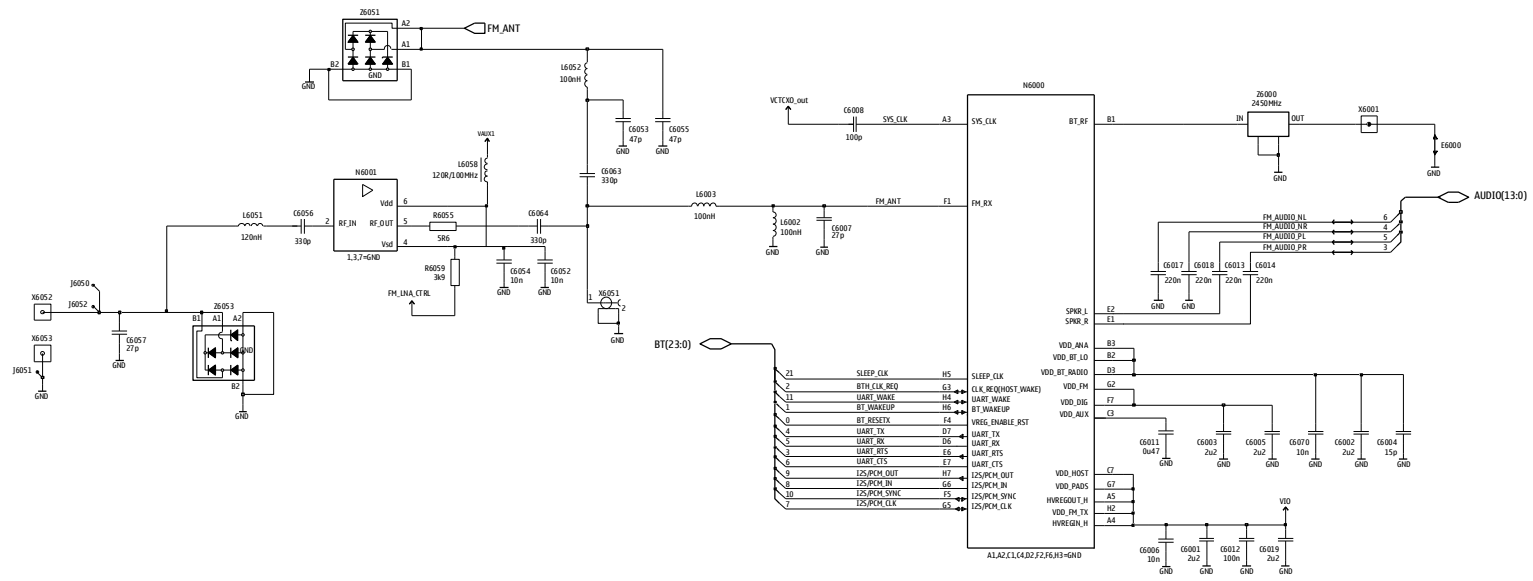

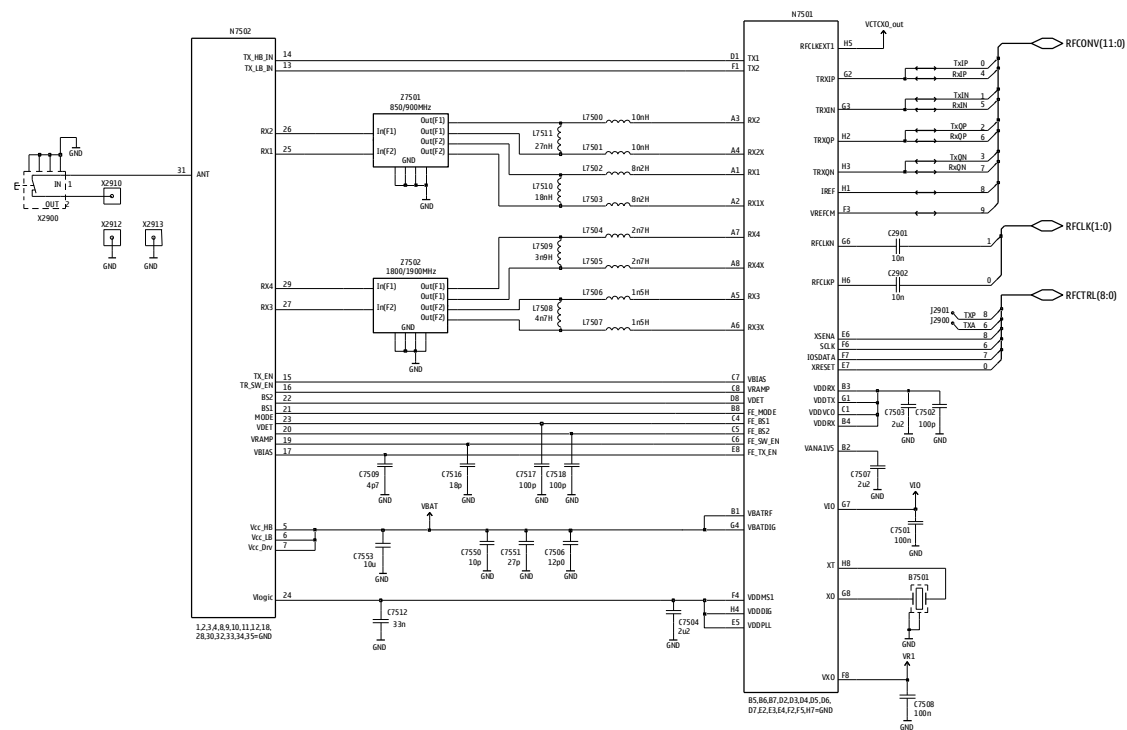

A	G247	M3	C2821	I3	E2102	R8	L7507	G5	R2596	E4	
A2700	L7	G249	N5	C2823	K2	E2104	R7	L7508	G5	R2597	BB
A7500	G5	C265	M3	C2824	K2	E2105	SB	L7509	G5	R2598	E7
A7501	L4	C266	M3	C2828	I3	E2106	SB	L7510	G5	R2599	E5
A7502	P9	C267	L4	C2829	L3	E2120	G6	L7511	G5	R2700	M5
A7503	P7	C268	M3	C2890	J2	E2121	F4	L7510	E6	R2803	I4
A7504	G3	C271	N8	C2891	I2	E2122	E6	M	R2804	I4	
B	G275	N5	C2901	I5	E2123	G4	M2100	K10	R2880	L4	
B2104	D10	C280	N3	C2902	I5	E2124	R2	N	R2881	L4	
B2200	M3	C281	N6	C3200	I10	E2125	P4	N2002	O7	R2882	L4
B7501	H5	C282	N4	C3201	H7	E2126	P2	N2100	N5	R2883	L3
C	C285	N8	C6001	G3	E2127	R4	N2200	M4	R2884	L4	
C2001	O7	C294	L3	C6002	G3	F	N2460	K2	R2885	L4	
C2002	P6	C296	N3	C6003	G3	F2001	P7	N2500	O8	R2886	L4
C2003	P7	C314	N4	C6004	G3	F2050	O2	N6000	G3	R2887	L3
C2004	P7	C315	N8	C6005	G4	L	N6001	G2	R2888	L4	
C2050	O3	C2316	M3	C6006	G4	L2001	P7	N7501	H5	R2890	J2
C2051	O3	C2317	M3	C6007	F4	L2050	O2	N7502	F5	R2891	J2
C2081	F9	C2318	O4	C6008	G3	L2080	I2	R	R6054	F3	
C2082	L2	C2319	N3	C6009	G3	L2100	F10	R2022	O6	R6055	F2
C2083	E9	C2326	N8	C6010	F3	L2101	P7	R2023	P6	R6059	F2
C2084	F7	C2347	O5	C6011	G3	L2102	E3	R2024	P7	S	
C2086	E9	C2352	M5	C6012	G4	L2103	E3	R2025	P6	S2501	M2
C2100	P7	C2353	M5	C6013	F4	L2105	P7	R2030	O3	S2502	O2
C2101	F10	C2365	L4	C6014	F3	L2106	N5	R2081	O7	S2503	D2
C2102	F3	C2460	K2	C6017	F4	L2110	N6	R2082	F7	V	
C2103	E3	C2480	O6	C6018	F4	L2120	K5	R2100	L4	V2300	N4
C2104	E10	C2481	R7	C6019	G3	L2121	K5	R2103	SB	V2310	N4
C2105	P7	C2482	S7	C6052	G2	L2122	L5	R2106	F3	V2440	J2
C2108	J10	C2485	R7	C6053	F2	L2123	L5	R2107	F2	V2441	J2
C2116	L5	C2499	P8	C6054	G2	L2124	O5	R2116	P4	V2500	E5
C2117	K5	C2500	O4	C6055	F2	L2125	O5	R2117	P4	V2501	O7
C2118	L5	C2501	O4	C6056	G2	L2126	J5	R2120	F10	V2502	D5
C2119	L5	C2502	O4	C6057	H2	L2127	J5	R2121	J10	V2503	E7
C2120	P7	C2503	O4	C6063	F2	L2128	L5	R2123	J10	V2505	O3
C2121	P7	C2504	K2	C6064	F2	L2129	L5	R2204	N8	V2549	P5
C2122	L4	C2505	L2	C6070	G4	L2130	E10	R2401	O5	X	
C2123	N6	C2506	L2	C7501	H5	L2131	E10	R2440	J2	X2003	T5
C2124	N5	C2507	K2	C7502	H6	L2132	N5	R2441	J2	X2080	E7
C2125	N6	C2508	K2	C7503	H6	L2300	O4	R2443	J2	X2100	S8
C2126	M5	C2509	K2	C7504	H6	L2310	O3	R2444	J2	X2401	R6
C2127	N5	C2510	K2	C7505	H5	L2311	P4	R2460	K2	X2520	P9
C2128	M5	C2518	P8	C7506	H6	L2340	O5	R2501	P8	X2700	K8
C2129	M5	C2519	P7	C7507	H6	L2347	O4	R2502	K2	X2900	D7
C2130	M5	C2595	E4	C7508	H5	L2400	O7	R2505	O3	X2910	C7
C2132	N5	C2596	E4	C7509	H5	L2500	O4	R2506	O4	X2912	CB
C2140	K5	C2598	P7	C7512	G6	L2501	O4	R2507	P8	X2913	C7
C2141	K5	C2599	O7	C7513	G6	L2506	P8	R2508	P8	X3200	CB
C2150	I10	G2700	L6	C7514	G6	L2507	P8	R2518	O9	X6001	E2
C2151	I10	G2800	K5	C7515	G6	L2547	E7	R2519	P9	X6051	F4
C2197	P5	C2801	L4	C7516	G6	L2548	E5	R2537	E7	X6052	H2
C2198	P5	C2804	L3	C7517	G6	L2549	D7	R2538	E5	X6053	N10
C2199	P5	C2805	I5	C7518	G6	L2550	F4	R2539	E5	Z	
C2200	N5	C2806	J2	C7519	G6	L2599	P8	R2540	D7	Z2101	N5
C2211	N8	C2807	J2	C7520	H5	L3200	I10	R2547	P6	Z2102	N5
C2213	N8	C2808	J5	C7550	F6	L6002	F4	R2548	P9	Z2500	O8
C2214	N4	C2809	J2	C7551	G7	L6003	F4	R2549	P5	Z2501	P8
C2215	P3	C2810	K5	C7552	G7	L6051	G2	R2550	P8	Z2550	K2
C2222	L4	C2811	L4	C7553	E5	L6052	F2	R2552	O9	Z6000	F3
C2228	L3	C2812	L3	C7554	E5	L6058	G2	R2553	P9	Z6051	G2
C2229	N4	C2813	J2	D	L7500	G5	R2554	P9	Z6053	G2	
C2230	N8	C2814	J2	D2800	K4	L7501	G5	R2555	P9	Z7501	G5
C2231	O5	C2816	I4	D3000	K4	L7502	G6	R2587	E4	Z7502	G5
C2232	L5	C2817	K5	E	L7503	G5	R2588	E2			
C2233	O4	C2818	J2	E1000	S6	L7504	G5	R2589	E2		
C2234	O5	C2819	I4	E2100	S8	L7505	G5	R2594	E7		
C2245	N4	C2820	I3	E2101	Q8	L7506	G5	R2595	E7		

